	WOODEN STICKS FOR ICE-CREAM PADDLE 93	SP-FP-44
		Rev. 03
	93 x 17 x 2 mm	02.05.2023

1. Product description

Wooden ice cream sticks 93 x 17 x 2 mm, wax coated, loose or bundles, made from beech. The sticks are approved for direct contact with food.

2. Product composition

- **Components:** sticks are made from **virgin beech wood** (99.8%), covered with a thin layer of **food grade vegetal-wax** (0.2%), used for automatic insertion into ice-cream.
- **Vegetal wax** follows the regulations of EC 1935/2004, EC 2023/2006, (EU) PIM No 10/ 2011.
- **Product code for waste identification: FOR 50**, according with European Commission Decision 97/ 129/EC for all packaging materials covered by Directive 94/62/EC, amended by Directive (EU) 2018/852 - Packaging and packaging waste.
- **Recycled materials:** product doesn't contain any recycled materials.
- **Caution:** Wooden ice cream sticks are designed to be use in direct contact with food, without being consumed as such (stick itself). Food manufacturer is responsible to provide correct information to the end consumer.



3. Microbiological and chemical parameters (monitoring)

The results obtained from microbiological, and physico-chemical analyzes are in accordance with the legal requirements, customers requirements and with our contaminants plan.

4. Product details:

a. Sticks	
Decoration	Branded (pyro-gravure) or not-branded.
Colour	Light to reddish-brown.
Edge	Bevelled, even and clean.
Surface	Surface must be smooth and without residual dust.
b. Boxes	
Carton	Made from food approved cardboard, closed with paper tape, glue or self-closing, clean and dry, without dust and undamaged.
Pallets	Covered with a sheet of cardboard at the bottom, stretch wrapping foil and protected with a plastic on top.

5. Storage and distribution conditions:

Temperature & Relative Humidity	In a clean and dry place far from sunshine and from high humidity.	
Shelf life	2 years	
Caution	Keep out of direct water spray and rain.	
Food contact materials symbol	The sticks are approved for direct contact with food.	

	WOODEN STICKS FOR ICE-CREAM PADDLE 93	SP-FP-44
	93 x 17 x 2 mm	Rev. 03
		02.05.2023

6. Quality inspection and product release:

Product Quality Inspection is done based on the sampling method in accordance with ISO 2859-1/1999 Standard:

- One product batchcode (lot) correspond to 1 pallet; 1 pallet may contain boxes produced on only one or more shifts;
- Lot size (for one batch) $\geq 500,001$ pcs;
- Sampling plan: based on the lot size and general inspection level is use – **Code letter Q**; According with this code letter, sampling size corresponding is **1250 pieces**;
- According with this method product quality status [batch released or blocked] is based on 3 category of defects:

CRITICAL defects AQL: 0.01 [0 acc/1 reject]	MAJOR defects AQL: 0.04 [1 acc/ 2 reject]	MINOR defects AQL: 0.4 [10 acc/ 11 reject]
---	---	--

Summary with sampling plan and accept /reject criteria can be seen in Product Quality Standard – available on request.

7. In compliance with :

- ✓ EUTR (EU Timber Regulation no. 995/2010 - “wood from legal source (logging) traceable” based on batch code number.
- ✓ EC Regulation 1935/2004 “Any material in direct contact with food must be sufficiently inert not to deteriorate organoleptic properties.
- ✓ EC Regulation 2023/2006 - “any material in direct contact with food must be manufactured in compliance with general rules of good manufacturing practice”.
- ✓ European Commission Regulation (EU) PIM No 10/ 2011 of 14 January 2011 on plastic materials and articles intended to come into contact with food, as amended by date, last one Commission Regulation (EU) 2020/1245 of 2 Sep 2020.
- ✓ EC Regulation: 178/2002; 852/2004/EC; 396 /2005 EC; EuPIA (European Printing association); 3954/87 EC.
- ✓ Directive (EU) 2018/852 of the European Parliament and of the Council of 30 May 2018 amending Directive 94/62/EC on packaging and packaging waste and European Commission Decision 97/129/EC for all packaging materials.
- ✓ Regulation (EC) No 1895/2005 on the restriction of use of certain epoxy derivatives in materials and articles intended to come into contact with food.
- ✓ Regulation (EC) No 1907/2006 of the European Parliament and of the Council of 18 December 2006 concerning the Registration, Evaluation, Authorization and Restriction of Chemicals (REACH) as defined in REACH Article 59 (10).
- ✓ Romania Minister of Health Order ORD 1126/2006.
- ✓ Compliance with the US Food, Drug and Cosmetic regulation of the United States of America as set out in the Code of Federal Regulations of the US Food and Drug Administration (FDA), under 21 CFR. California’s PROP 65; CONEG
- ✓ French DG - CCRF Note information n° 2012-93.
- ✓ German BfR XXXVI- About products intended for contact with foodstuffs.
- ✓ Dutch FCM regulation Commodities Act Regulation on Packaging and Consumer Articles - ‘Warenwetregeling verpakkingen en gebruikersartikelen’
- ✓ Regulation (EU) No 1169/2011 on the provision of food information to consumers, and its amendments – substances or products causing allergies.
- ✓ Commission Regulation (EU) No 231/2012 of 9 March 2012 laying down specifications for food additives listed in Annexes II and III to Regulation (EC) No 1333/2008 of the European Parliament and of the Council.
- ✓ Regulation (EC) No 1895/2005 on the restriction of use of certain epoxy derivatives in materials and articles intended to come into contact with food.
- ✓ Compliance with Turkish Food Codex Regulation amending the Turkish Food Codex Regulation on materials and articles intended to come into contact with foodstuffs on 08 Feb 2019.

8. Parameters of sticks

Parameter	Min	Target	Maxim	UoM	Obs.
Length	92.5	93	93.5	mm	-
Width	16.5	17	17.5	mm	-
Waist width	9.0	10.3	11.5	mm	
Thickness	1.8	2	2.2	mm	-
Distorsion on thickness	2.8			mm	-
Weight*	160	170	180	g	100 pcs
Moisture content	-	-	13.5	%	-



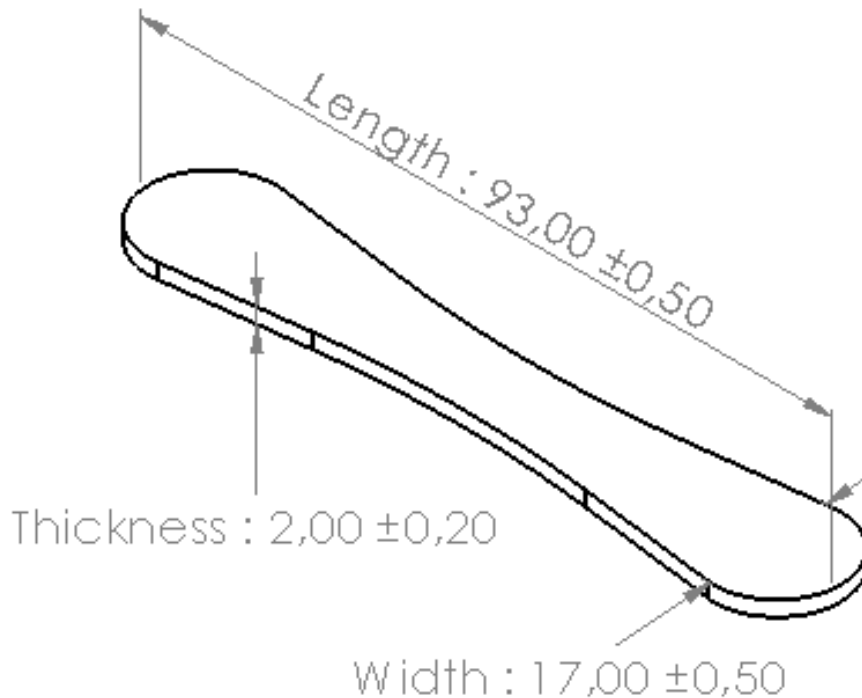

*Weight is calculated per on 100 sticks, therefore weight average for 100 pcs depends to the level of moisture.

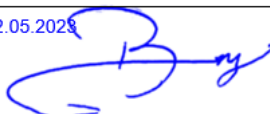

	WOODEN STICKS FOR ICE-CREAM PADDLE 93	SP-FP-44
		Rev. 03
	93 x 17 x 2 mm	02.05.2023

9. Annex 1: Packaging specification

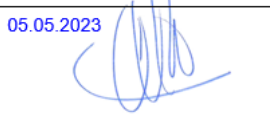
Boxes (2 types)	Loose sticks OPC: Rectangular boxes				Banded sticks OGC: Rectangular boxes	
	Open short side				Open long side	
	574 x 99 x 387 (swG) 580 X 99 X 391 (swR) 594 X 102 X 394 (swT) 565 x 103 x 390 (swC)				590 x 100 x 390 (swG) 594 x 98 x 400 (swR) 594 X 98 X 398 (swT) 590 x 100 x 390 (swC)	
	Proper filled box = full box – no space allowed					
Number of sticks/ small box*	5500				6500	6500
Number of sticks/banded*	-				63/64	50
Net weight / box* (estimated)	9.5 kg				11.5 kg	11.5 kg
Gross weight / box* (estimated)	10.0 kg				12.0 kg	12.0 kg
Euro pallet 800 x 1200 mm						
No. of boxes/layer	4	4	4	4	4	4
No. of layers /pallet	15	16	18	2 x 10	16	18
No. boxes / pallet	60	64	72	80	64	72
Total Height (cm)	170	180	200	230	180	200
Big euro pallet 1000 x 1200 mm						
No. of boxes/layer	5		5		5	5
No. of layers /pallet	16		2 x 9		2 x 10	18
No. boxes / pallet	80		90		100	90
Total Height (cm)	180		215		236	215
* The weight is estimated in accordance with technical acceptable limits.						
* Quantity as pieces: +/- 1% of declared quantity for individual case; Average of 5 cases must achieve declared quantity						

	Revision	Specification Approval		
	Made by:	Validated by:	Validated by:	Approved by:
Print name	George Boboi	Bruno HENRY	Jean-Philippe Canault	Maria Ghinea
Business role	Group Quality Deputy	Group Industrial Operations Director	Group Sales & Marketing Director	Group Quality Director
Date & Signature	02.05.2023 	05.05.2023 	05.05.2023 	05.05.2023 

This document enters into force starting with: 01.11.2023

Customer approval			
Print Name			
Business role			
Date & Signature		Stamp	

Note:

Customer is kindly asked to read, approve and return this document back. If supplier does not receive back approved specification within 15 business days, the specification is considered to be accepted and approved.